

seeding



filling



transplanting



labelling



denesting



handling



dibbling



depopping



trimming



washing



irrigation

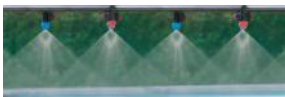

germination



NEW NEW NEW NEW N



URBINATI
Nursery Technology

URBINATI s.r.l.

Via della Liberazione, 18 - 47030 San Mauro Pascoli (FC) - Italy
Tel. (+39) 0541 932018 - Fax (+39) 0541 932679



www.urbinati.com - info@urbinati.com



IA3500

POTTING MACHINE - Pneumatic / Standard / Tech

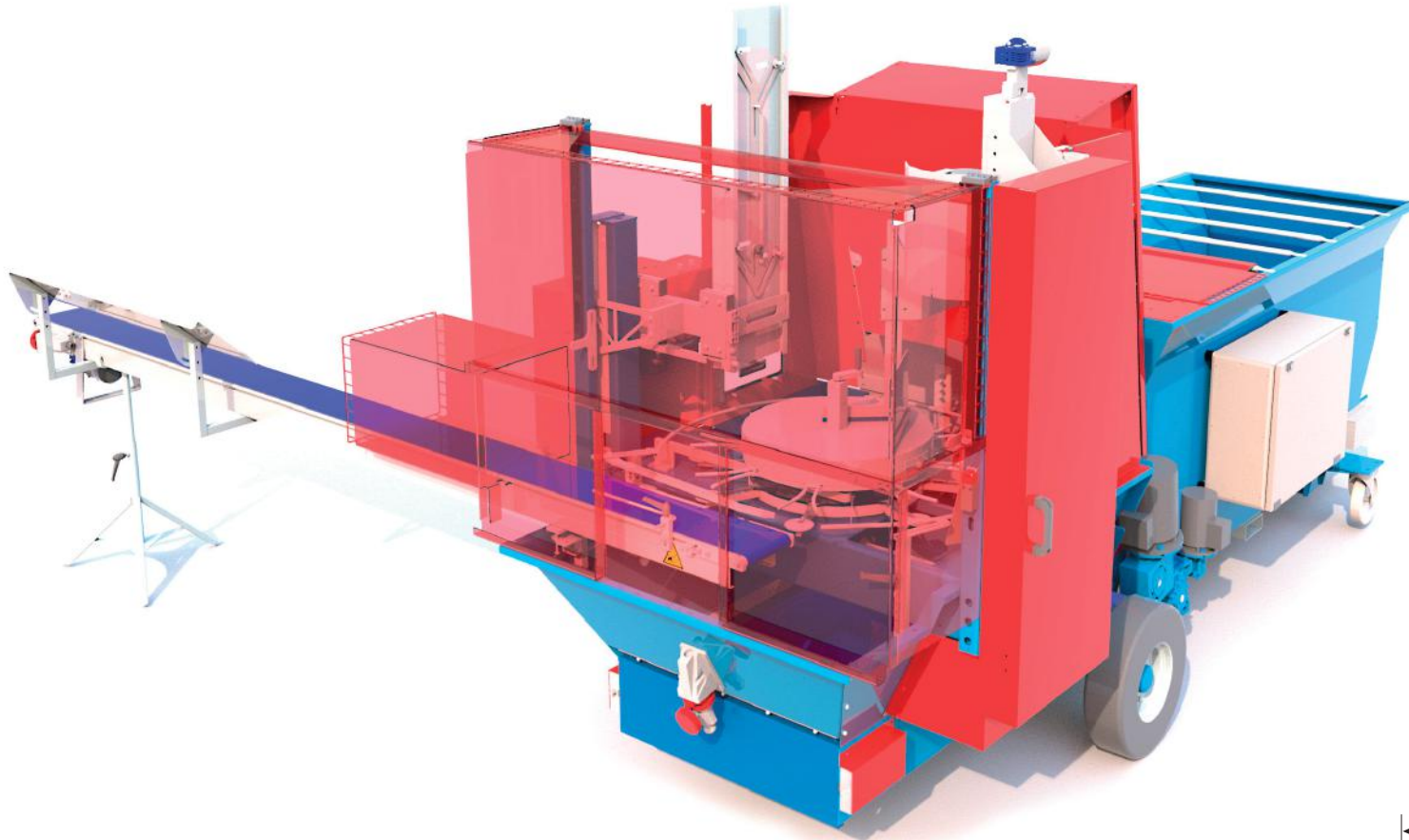

MACHINE DESCRIPTION

IA3500 is the potting machine of **new generation**: this version gives to the grower the opportunity to pre-program the settings for each specific pot size. This function enable to **reduce** considerably the **set-up times** when adapting to different pot diameters.

The pots denester, the drill depth, the hourly production, the speed of the working belt and the other **functions** of the potting machine are **controlled by a PLC** and they can be easily set from the colour touch-screen.

All settings can be programmed and saved by the operator; the last setting can be recalled with **just one touch**.

TECHNICAL DATA	M.U.	IA3500
HOPPER CAPACITY	l	1600
HOURLY PRODUCTION - Ø 8 cm (max)	pots/hour	4500
HOURLY PRODUCTION - Ø 25 cm (max)	pots/hour	2500
TRANSPLANTING BELT with trayholder	mm	(*) 3500
INSTALLED POWER	kW	5

(*) BELT LENGTH CUSTOMIZABLE ACCORDING CUSTOMER NEEDS

TECHNICAL SPECIFICATIONS

- For round pots from diameter **8 to 25 cm**.
- **Completely electromechanical**.
- **Fully-automatic** control soil feeding system.
- Motors are driven by **inverter**.
- Machine qualified as **energy saving**.
- **High safety standard machine**.

MAIN ACCESSORIES

- **Double head version** (pots Ø 8÷14 cm).
- **Feeding belt** for empty pots.
- **Fertilizer dispenser** (air comp. required).
- **Conveyor belt length**: 4000/5000/6000 mm.

